







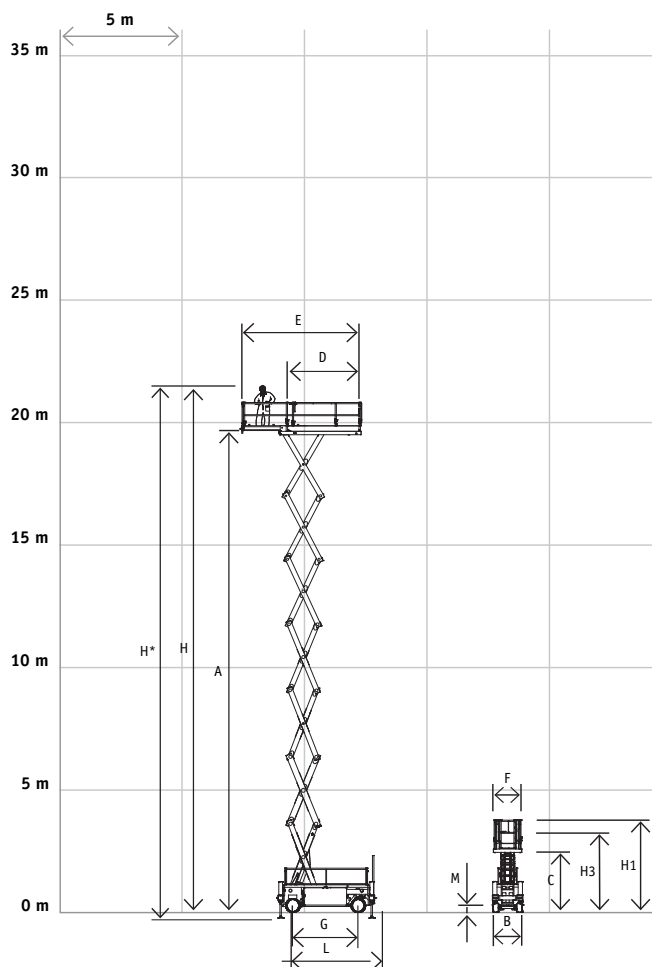

H (max.)	± 21.50 m
H* (max.)	± 21.74 m
A (max.)	± 19.50 m
C (min.)	± 2.58 m
DxF (min.)	3.38 x 1.16 m
ExF (max.)	4.88 x 1.36 m
H1	3.74 m
H3	3.01 m
LxB	4.05 x 1.26 m
G	2.67 m
M/N	148 mm/235 mm
∅ D	± 00 0
 (max.)	500 kg (2 pers. + 340kg)
 (max.)	500 kg (2 pers. + 340kg)
 (sec.)	90/55 sec.
	2.0 km/h
	0.5 km/h
	22 x 9 x 16
 (max.)	± 20%
	500 Ah/k5/48 V
 KG	9.800 kg



OPTIONS
Controlbox with quick disconnect
Hourmeter
Charger (high frequency)
230V supply on platform
Driving at full height
Driving, proportional
Differential lock
Lubrication system Easy Lube
Levelling jacks (N)
SAFETY FEATURES
Scissor skirt
Descent safety
Drive alarm
Emergency descent
APPLICATION
Indoors
Outdoors
Certified min. temperature -15°C