









H (max.)	± 21.50 m
H* (max.)	± 21.74 m
A (max.)	± 19.50 m
C (min.)	± 2.58 m
DxF (min.)	3.38 x 1.16 m
ExF (max.)	4.88 x 1.36 m
H1	3.74 m
H3	3.01 m
LxB	4.05 x 1.26 m
G	2.67 m
M/N	148 mm/235 mm
∅ D	± 00 0
 (max.)	500 kg (2 pers. + 340kg)
 (max.)	500 kg (2 pers. + 340kg)
 (sec.)	90/55 sec.
	2.0 km/h
	0.5 km/h
	22 x 9 x 16
 (max.)	± 20%
	500 Ah/k5/48 V
 KG	9.800 kg



**OPTIONS**

- Controlbox with quick disconnect
- Hourmeter
- Charger (high frequency)
- 230V supply on platform
- Driving at full height
- Driving, proportional
- Differential lock
- Lubrication system Easy Lube
- Levelling jacks (N)

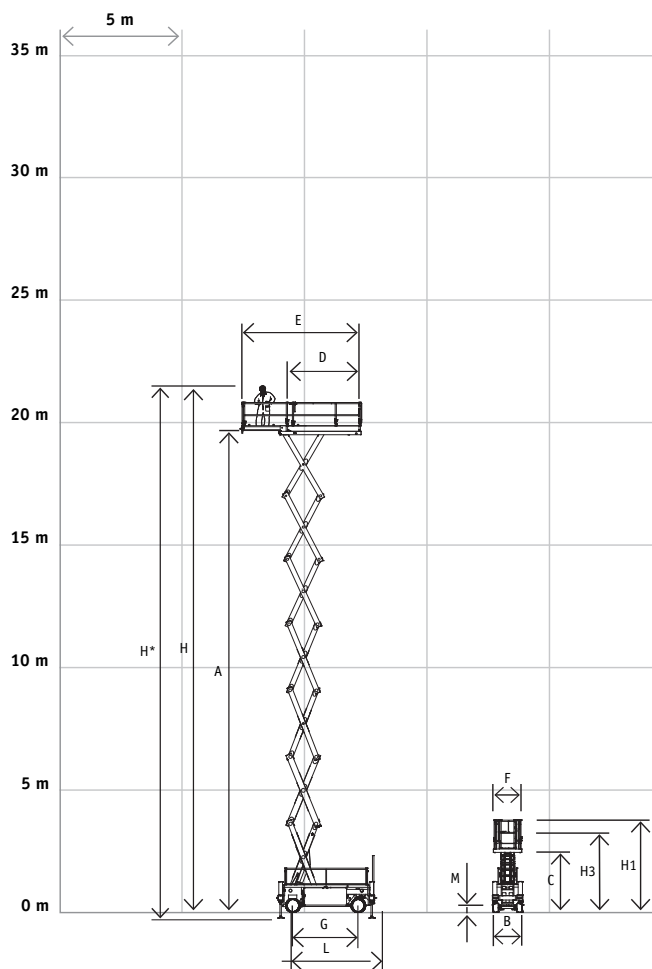
**SAFETY FEATURES**

- Scissor skirt
- Descent safety
- Drive alarm
- Emergency descent

**APPLICATION**

- Indoors
- Outdoors
- Certified min. temperature -15°C