

**STANDARD SPECIFICATIONS**

Performance	Indoor	Outdoor
Platform Height–Elevated	47-ft / 14.3-m	47-ft / 14.3-m
Platform Height–Lowered	5-ft 4-in / 1.6-m	5-ft 4-in / 1.6-m
Platform Capacity	800-lb / 363-kg	800-lb / 363-kg
Capacity on Platform Extension	300-lb / 136-kg	300-lb / 136-kg
Number of Occupants	3	2
Lift / Lower Time	76/58 seconds	76/58 seconds
Maximum Drive Height	Fully Elevated	Fully Elevated
Weight w/One Extension*	15,200-lb / 6,909-kg	15,200-lb / 6,909-kg
Drive Speed–Lowered	3.5 mph / 5.6 km/h	3.5 mph / 5.6 km/h
Drive Speed–Raised	0.5 mph / 0.8 km/h	0.5 mph / 0.8 km/h
Gradeability	35%	35%
Max Tilt Rating - Side-to-Side	2.5 Degrees	2.5 Degrees
Max Tilt Rating - Fore and Aft	3 Degrees	3 Degrees
Turning Radius - Inside	83-in / 2-m	83-in / 2-m
Turning Radius - Outside	175-in / 4-m	175-in / 4-m

\* Certain options or country standard will increase weight.

**Power Source**

Drive (2WD)	AC Electric Drive
-------------	-------------------

**Tires**

Non-Marking	26-in x 12-in Foam-filled
-------------	---------------------------

**Hydraulic System**

Capacity	13.2 gal / 50 L
----------	-----------------

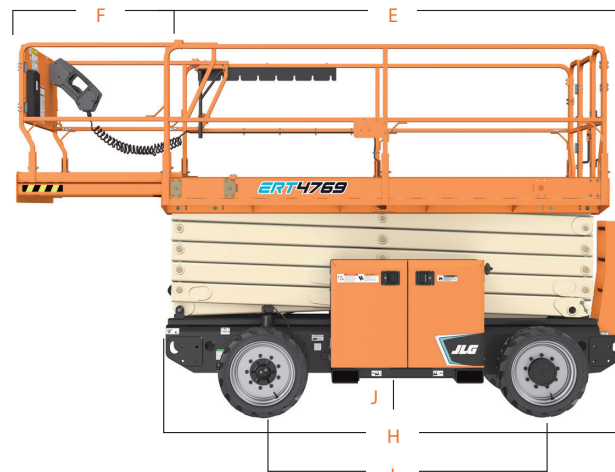
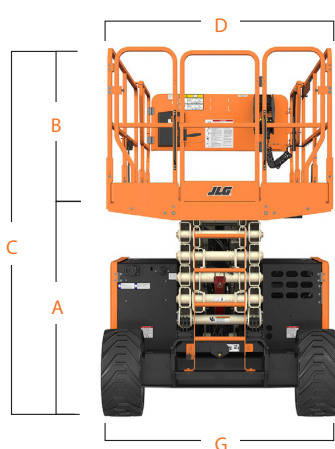

- A. Platform Height – Lowered 5-ft 4-in / 1.62-m
- B. Platform Railing Height 44.7-in / 1.14-m
- C. Machine Height 109.1-in / 2.77-m
- D. Platform Width 63-in / 1.6-m
- E. Platform Length 130.5-in / 3.3-m
- F. Platform Extension 42-in / 1.07-m
- G. Machine Width 69.3-in / 1.76-m
- H. Machine Length 139-in / 3.53-m
- I. Wheelbase 81.3-in / 2.07-m
- J. Ground Clearance 10.1-in / 25.7-cm