

STANDARD SPECIFICATIONS

Performance	Indoor	Outdoor
Platform Height (Elevated)	7.92-m	7.92-m
Platform Capacity	545-kg	545-kg
Capacity on Platform Extension	120-kg	
Number of Occupants	2	1
Lift / Lower Time (No Load)	47/44 seconds	47/44 seconds
Lift / Lower Time (Rated Load)	54/37 seconds	54/37 seconds
Maximum Drive Height	Fully Elevated	Fully Elevated
Weight*	2,389-kg 122	2,389-kg
Max. Ground Bearing Pressure	8.6 kg/cm ²	8.6 kg/cm ²
Drive Speed (Lowered)	4.8 km/h	4.8 km/h
Drive Speed (Raised)	0.8 km/h	0.8 km/h
Gradeability	25%	25%
Max Tilt Rating - Side-to-Side (Indoor)	2.5 Degrees	1.5 Degrees
Max Tilt Rating (Fore and Aft)	3.5 Degrees	3.5 Degrees
Turning Radius (Inside)	Zero	Zero
Turning Radius (Outside)	2.24-m	2.24-m

*Certain options or country standards increase weight

Power Source

Battery	4 x 6V 220 amp-hr
Charger	27 amp
Drive	Hydraulic Front-Wheel

Tires

Standard	406 x 127-mm
----------	--------------

Brakes

Multi-Disc Friction	
---------------------	--

Hydraulic System

Capacity	15 L
Pump	Fixed Displacement Gear

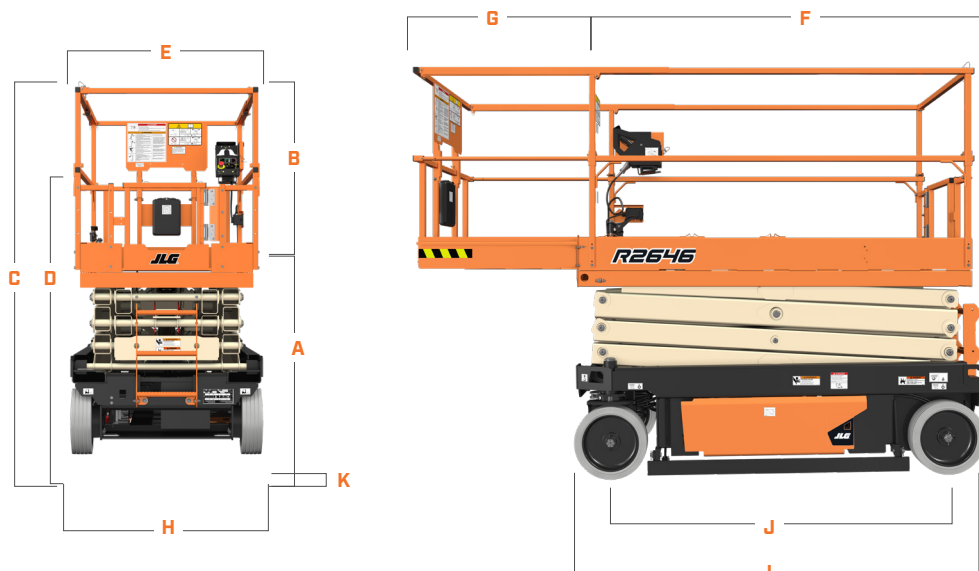

A. Platform Height (Lowered)	1.14-m
B. Platform Railing Height	1.1-m
C. Machine Height (Rails Raised)	2.28-m
D. Machine Height (Rails Lowered)	1.82-m
E. Platform Width	1.1-m
F. Platform Length	2.1-m
G. Platform Extension	91-cm
H. Machine Width	117-cm
I. Machine Length	2.4-m
J. Wheelbase	1.9-m
K. Ground Clearance	9.8-cm